





CONTENTS

The Company	03
DÉCOR by Sonite	05
Our upcycled materials	07
Trays and plates	10
Boxes and bowls	16
Cups	20
Placemats and coasters	24
Planters	28
Basins	30
Notebooks	32
Materials and colors	34
Models and dimensions	36
Product guide	39
Customization	40
Contact	40



THE COMPANY

The determination to get closer to nature was the impetus behind our development of a series of items entailing upcycling of waste materials that were creating problems for our community. The nature of, and in, our products allows us to reach far beyond what we thought possible.

Our passion is innovation, but we don't want to pay any price for it. Instead, we want to leave a good mark in the society we live in by turning waste challenges into high-value upcycled accessories.

As industrialists, we provide quality, efficiency and solidity but are mindful of a contract with nature. Therefore, our technology is applied in a hand-crafted manner, allowing every single piece of our designs to be unique in its own way.

This is what we see as the future of design.



DÉCOR BY SONITE

Sonite's DÉCOR is the result of our concern for the environment combined with our passion for innovation and design. Our products are crafted from innovative materials with all the lower-carbon footprint properties associated with our signature lightweight composites.

Rice husks, old banknotes, coconut fibers, thermoset plastics and ocean bound plastics are elements we upcycle into objects that enhance the look and feel of the original discarded products. We collect these raw materials from our neighboring communities, reducing pollution resulting from waste burning and dumping in landfills, fields and oceans.

Our design objects are an evolving collection of boxes, bowls, trays, cups, coasters, planters, basins and other items that exude natural beauty.

We have transformed unwanted materials into beautiful new accessories of high value and notable substance that can be used as impressive eco-luxury packaging. They all enhance their original raw materials and follow the principles of strength and durability. We do not do single-use products.

Available in different colors, our DÉCOR objects strike the perfect balance between refined natural beauty and modern elegance.

All our objects are made from locally-sourced leftovers. Since the production process is all in-house, OEM and custom design inquiries are possible.



OUR UPCYCLED MATERIALS

Our collection is made of innovative upcycled materials that allow us to create beautiful objects, reducing waste in the process by transforming left overs into marketable products. These are our unique materials:

Husk™ is made of rice husks discarded as part of the milling process in agriculture. It is a highly stable material with exceptional longevity and durability. The bio-composite Husk™ allows us to create objects that are both appealing and environmentally friendly while reducing waste from rice agriculture.

Kasse™ is a colorful material made of upcycled banknotes. The colored background of the bills, combined with the brilliant accents from the security features create an avant-garde effect that makes Kasse™ a never-seen-before design. Sonite collaborates with the Bank of Thailand to upcycle used banknotes that cannot be recycled.

Cocco™ is made from coconut fibers. The original strands of the shell give the material an organic feel and strength. With a production of over one million tonnes annually, a large amount of coconut waste is produced in Thailand. By upcycling it, we contribute to a better environment.

Scapa™ is an innovative material that resembles reconstituted stone made from used thermoset plastic. As the raw material is highly resistant to heat, it cannot be melted and recycled. By crushing and mixing it with our high grade polymers, we create an innovative material with all the lower-carbon footprint properties associated with our signature lightweight composites.

Naturla™ is an elegant material made of natural stone. By peeling a thin layer from a block, we can produce beautiful stone elements of very low weight, and reduce their carbon footprint.

Talay™ is a highly resistant material made from ocean-bound plastic waste. Its beauty resides in the very dramatic effect that results from the random solidification of the original plastic pieces. Ocean-bound PET (polyethylene terephthalate) plastic waste is a public health hazard. By upcycling it, we are reducing potential ocean pollution.



TRAYS AND PLATES

Our collection of trays and plates is designed to deliver the perfect combination of beauty and functionality. Made in a range of oval and rectangular shapes and sizes, they can be fashioned in multiple colors and materials.

To serve a breakfast in bed, present a dish in a restaurant, carry a coffee to a table, or to leave your keys and wallet, our upcycled trays are the perfect tool for cafeterias, eco-luxury hotels and home use.



Oval and Round Tray in Husk



Serving Tray in Scapa

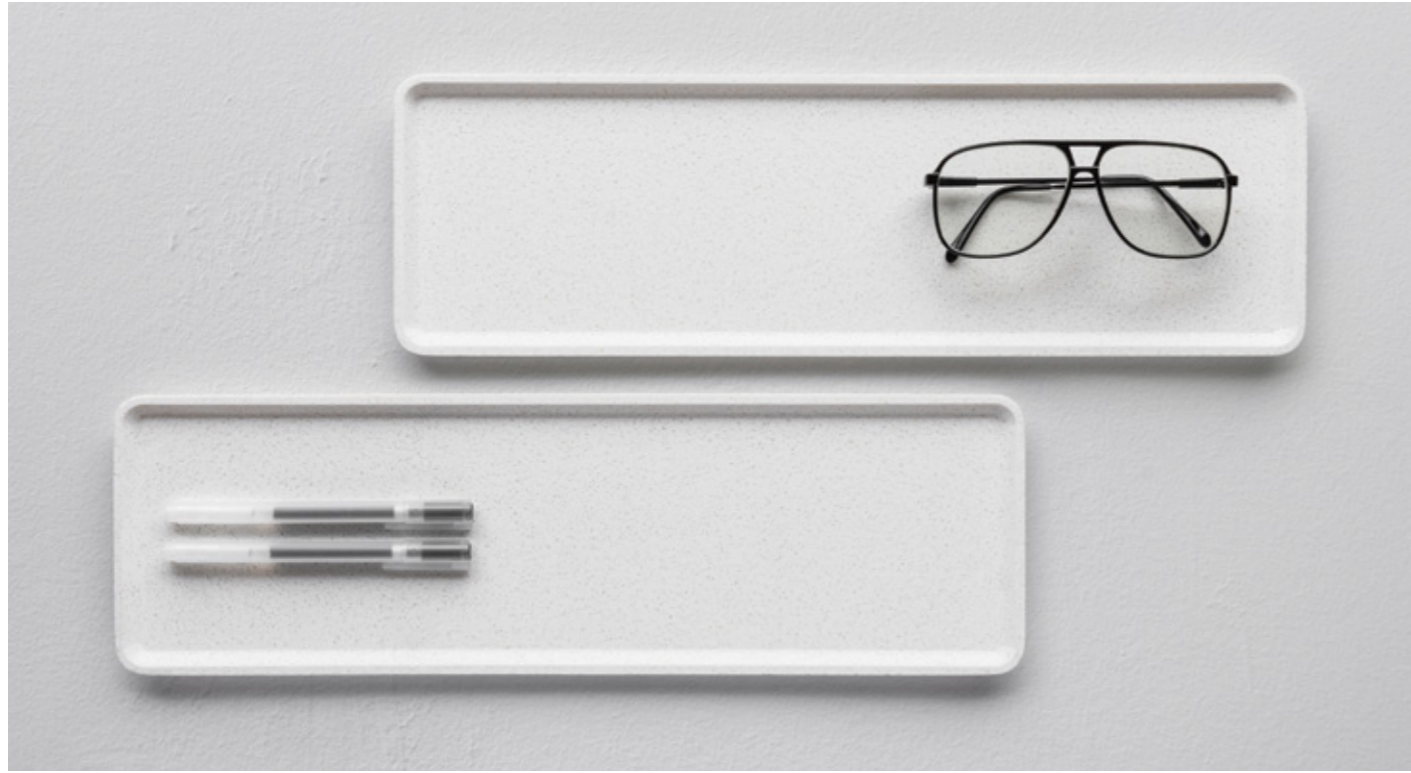

Long Tray in Scapa



Plate in Cocco



Tea Tray in Husk



BOXES AND BOWLS

Our collection of boxes and bowls is not just a set of functional containers. It is a range of design objects that delivers a personal touch to a space. Available in multiple colors and shapes, our upcycled boxes and bowls are a lovely display of organic materials.

The shape and size of our bowls make them perfect for serving your cooking creations. Colorful and elegant, they are available in Husk and Cocco materials.

Sonite's Jasmine boxes are beautiful, multi-functional containers suitable for any area of the house. And our Tagine boxes come in two shapes that are perfect for storing small-size items or adorning a bathroom or a bedside table.



Bowl in Husk



Jasmine boxes in Cocco



SONITE

SONITE

SONITE

SONITE

SONITE

SONITE

SONITE

CUPS

Our collection of cups consists of three models. Our Capsule cup is ideal for tea and coffee, and includes a lid to keep your favorite beverages warm. The Sake cup is a small glass influenced by the Japanese drinking tradition. Wonder cup was inspired by the Wonderfruit Festival and is perfect for outdoor use.

Available in Husk and Cocco, our upcycled cups are the perfect expression of an eco-design.



Capsule cup in Husk



Sake cup in Husk



PLACEMATS AND COASTERS

Our natural stone composites will give a touch of refinement and sophistication to your table, with patterns and shapes that only the earth can create. Hand crafted from natural stone blocks, our placemats and coasters combine natural beauty and modern elegance.

For commercial use, we have created two coaster sets. They are available in different materials and colors that will resist any condition whilst delivering an eco touch to your venue. Fully reusable and washable, our upcycled coasters can be branded and are perfect for bars and hotels.



Coaster Plain Set in Husk



Coasters in Natura



PLANTERS

Our upcycled materials are the perfect match for your plants, inspiring curiosity and helping bring new textures and colors to your home or garden.

Sonite's collection of planters consist of two models: a small decorative pot for tiny greenery and a larger vertical planter that can be easily hung by its top ring. Suitable for outdoor and indoor use, they are lightweight and can be stacked.



Planter Tail in Kasse



Planter Small in Kasse

BASIN

In the process of designing upcycled decorative objects, an important element to consider is the carbon footprint of the elements we create. That is what led us to produce a basin that combines the high resistance of our upcycled materials with a much lighter weight than most of the conventional products in the market.

The result is a light and elegant design that challenges convention and will fit in any context thanks to our wide range of materials and colors.



Basin in Scapa



NOTEBOOKS

For sketching, planning your week or writing down your shopping list, our upcycled notebooks are the perfect ally for your every day needs. Designed in standard A4, A5 and B5 sizes and available in more than 15 colors and textures, our notebooks are your perfect companion for work or home.



Notebooks in Kasse



MATERIALS AND COLORS

Our innovative materials deliver textures and colors related to the nature of their source. Husk, Cocco and Naturla follow their bio-composite origin and organic essence. Kasse is the result of upcycling used Thai baht banknotes. Scapa and Talay take their color, texture and transparency from their original plastic components. The result is a creative palette of eco-luxury colors and textures.

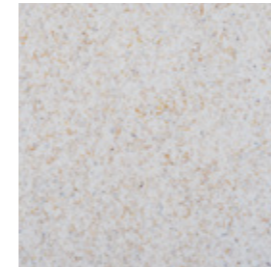

HUSK DUNE
REF. RHX-017

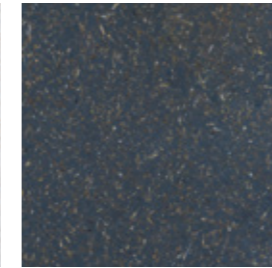

HUSK SHADOW OAK
REF. RHX-910

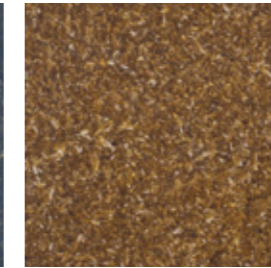

HUSK CORNSILK
REF. RHX-800

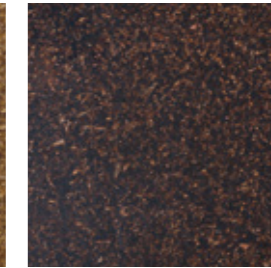

HUSK WALNUT
REF. RHX839

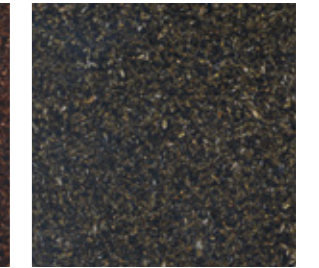

HUSK CHARCOAL
REF. RHX-999

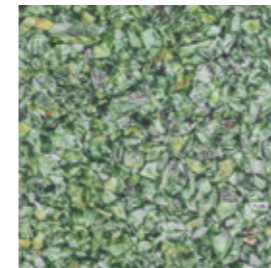

KASSE GREEN
REF. KSX-020

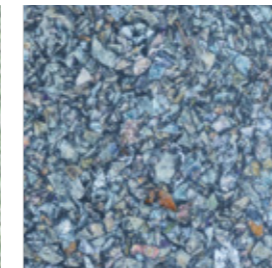

KASSE BLUE
REF. KSX-050



KASSE RED
REF. RSX-100

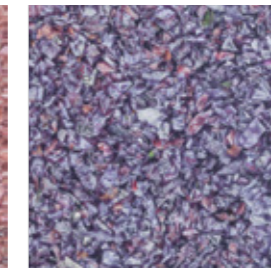

KASSE PURPLE
REF. KSX-500

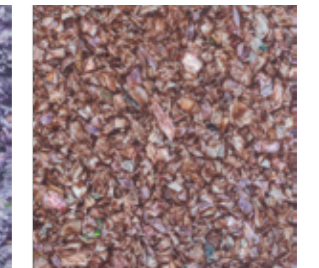

KASSE GRAY
REF. KSX-01K



COCCO CREAM
REF. CFX-017

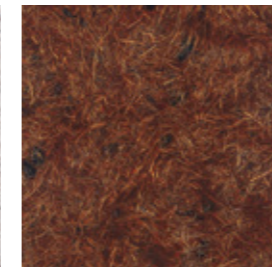

COCCO ORANGE
REF. CFX-360



COCCO GREEN
REF. CFX-449

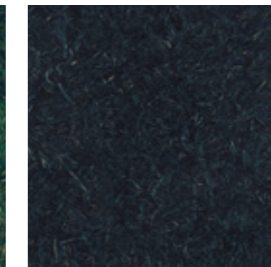

COCCO BLUE
REF. CFX-669

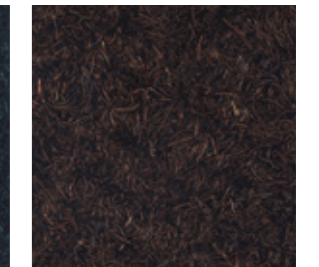

COCCO NUT
REF. CFX-886



NATURLA LIGHT
REF. NSX-1104

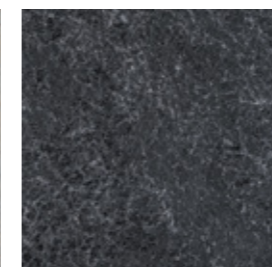

NATURLA GRAY
REF. NSX-1017

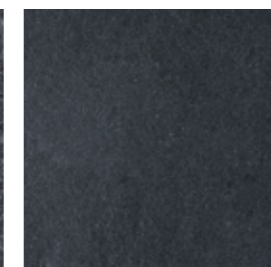

NATURLA BLACK
REF. NSX-1010

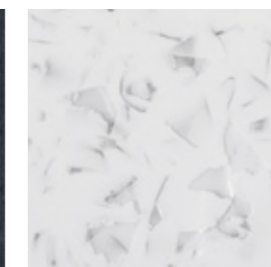

TALAY WHITE
REF. TAX-001



TALAY TRANSLUCENT
REF. TAX-002

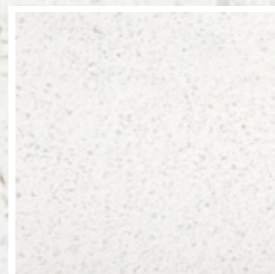

TALAY WHITE
REF. TAX-001

MODELS AND DIMENSIONS

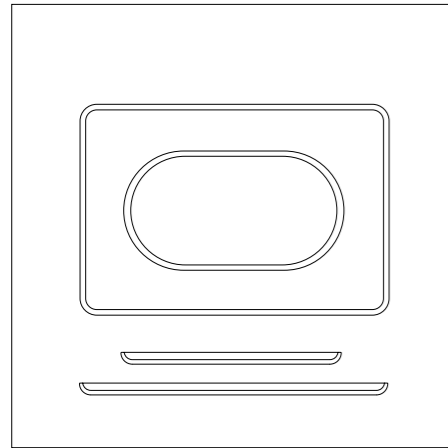

CAPSULE TRAY
S: 196x106x11mm M: 222x152x12mm

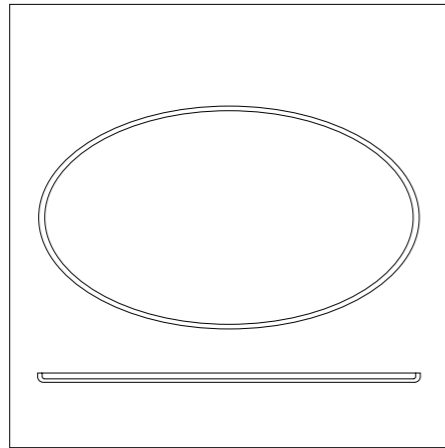

OVAL TRAY
272x191x12mm

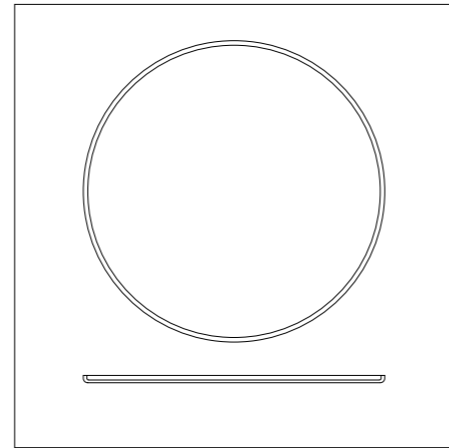

ROUND TRAY
Ø330x8mm

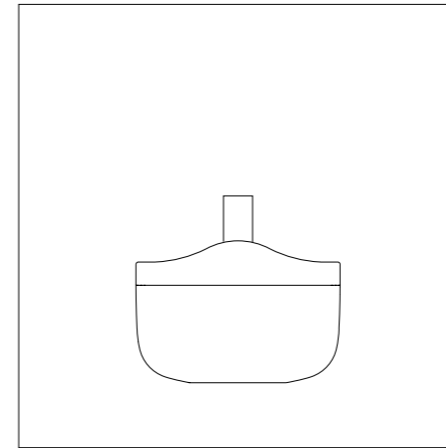

TAGINE
110x75mm

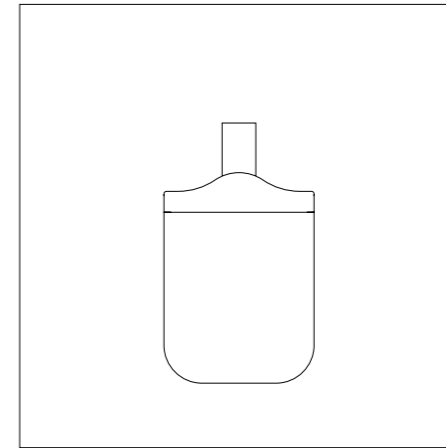

TAGINE TALL
79x110mm

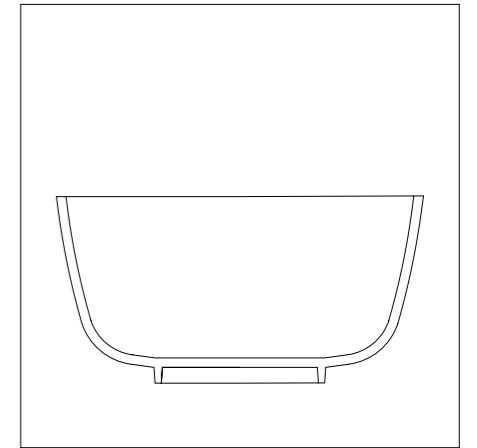

BOWL
234x119mm

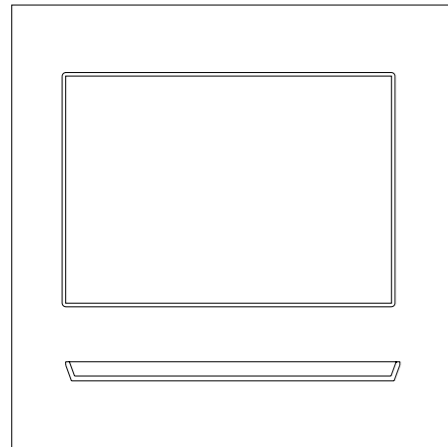

TEA TRAY
M: 272x191x16mm L: 405x305x20mm

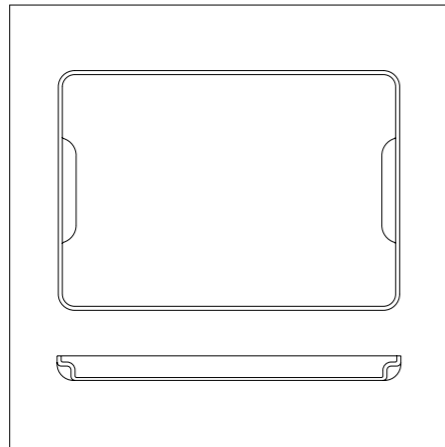

SERVING TRAY
424x298x30mm

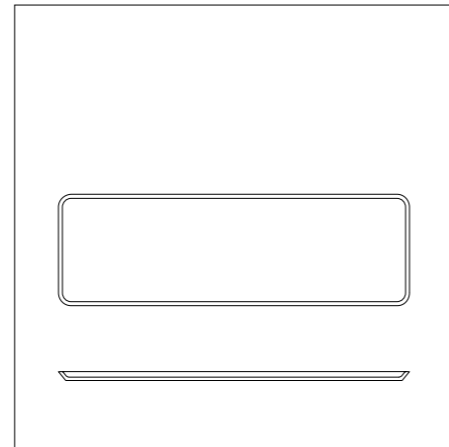

LONG TRAY
423x131x10mm

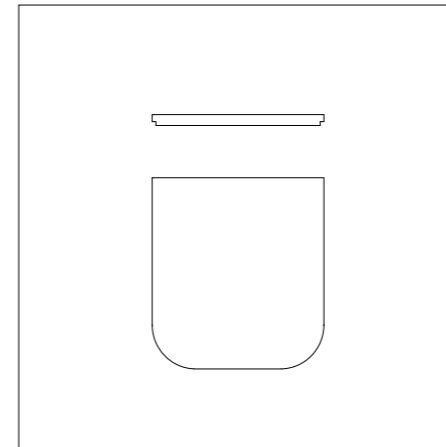

CAPSULE CUP
80x90mm

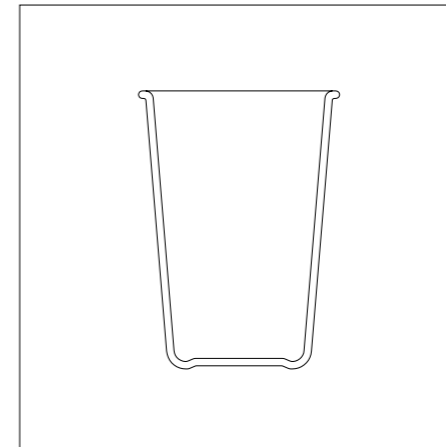

WONDER CUP
93x131mm

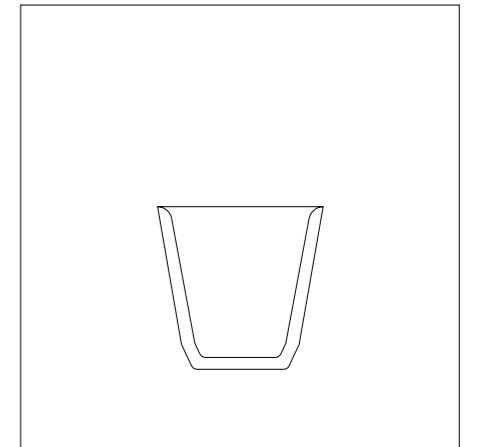

SAKE CUP
56x56mm

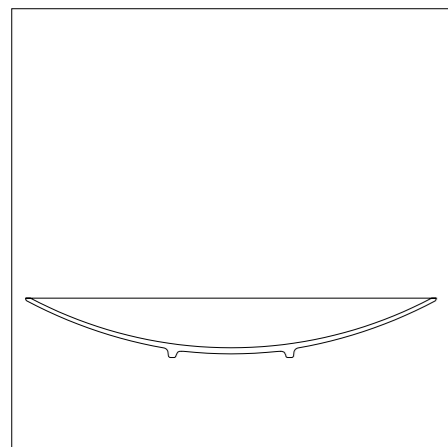
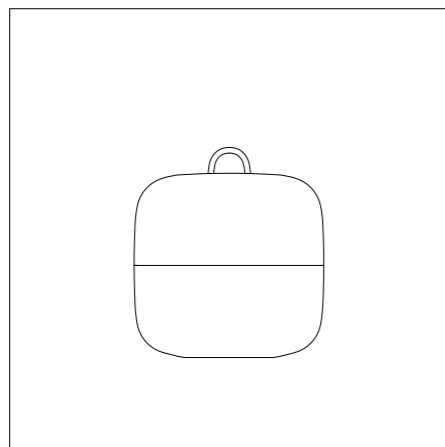
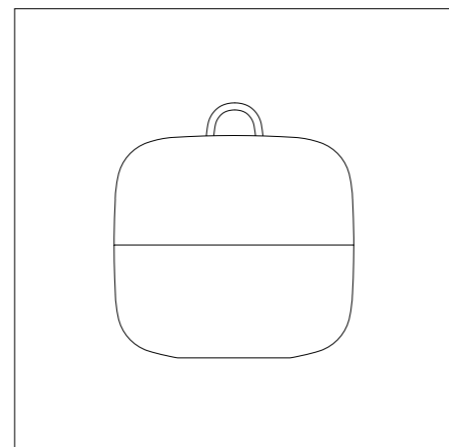

PLATE
403x59mm



JASMINE BOX S
109x104mm



JASMINE BOX M
144x134mm

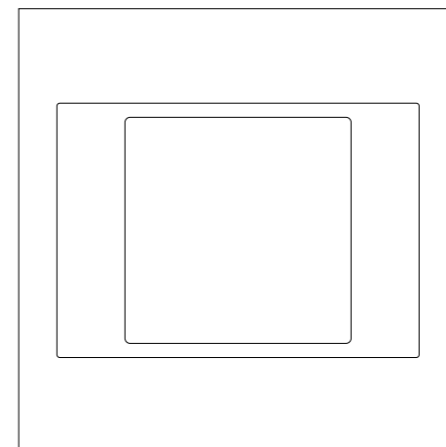

PLACEMAT SQUARE
S: 196x196mm L: 508x356mm

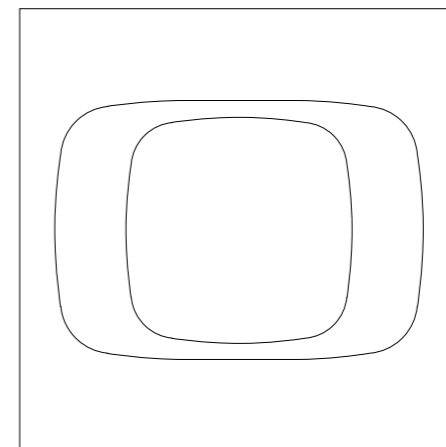

PLACEMAT PILLOW
S: 196x196mm L: 508x356mm

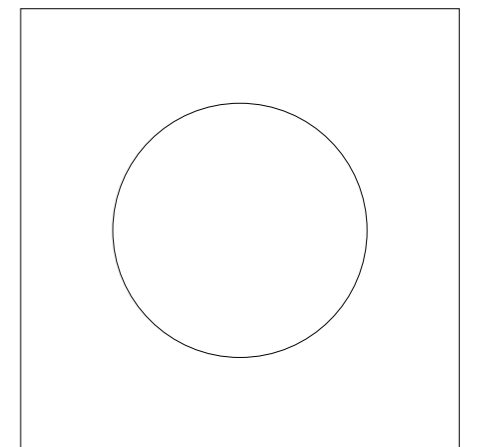

PLACEMAT ROUND
M: Ø196mm L: Ø295mm XL: Ø358mm

MODELS AND DIMENSIONS

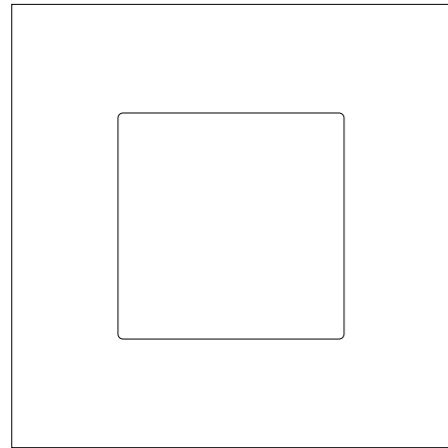

COASTER SQUARE
98x98mm

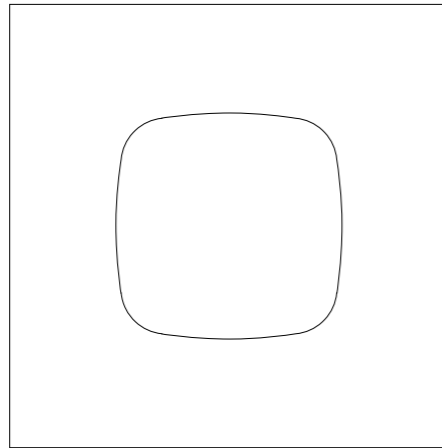

COASTER PILLOW
98x98mm

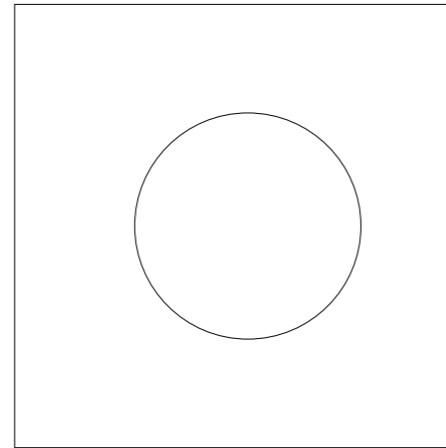

COASTER ROUND
Ø98mm for Naturla
Ø101mm for Husk, Kase, Coco

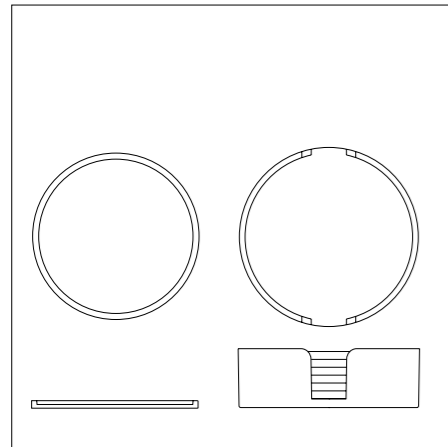

COASTER PLAIN (SET OF 6)
Coasters Ø105x10mm / Box Ø109x34mm

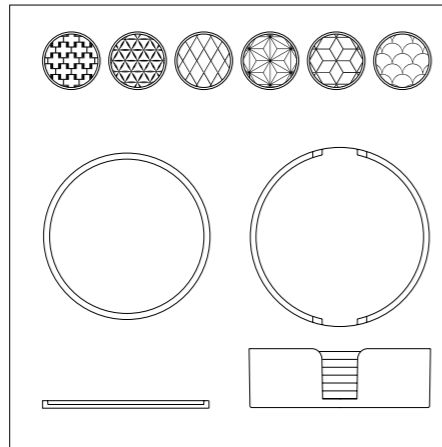

COASTER PATTERN (SET OF 6)
Coasters Ø105mm / Box Ø109x34mm

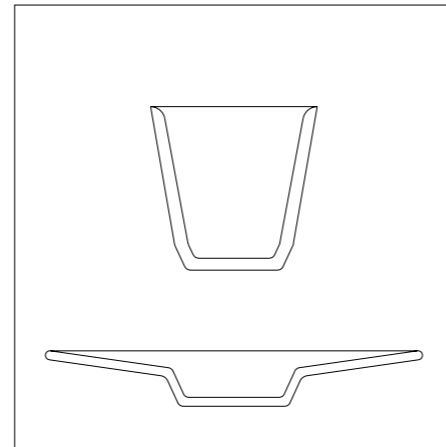

PLANTER SMALL
Pot 56x56mm / Plate Ø129mm

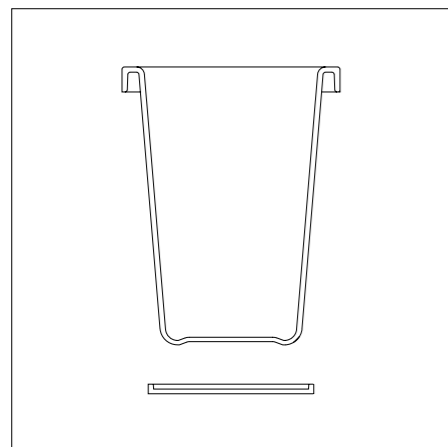

PLANTER TALL
Pot 138x176mm / Plate Ø101mm

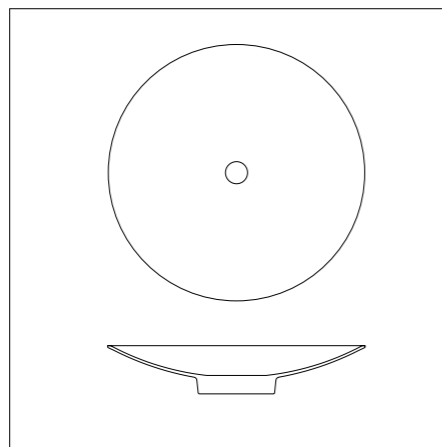

BASIN
403x75mm, Ø403mm, hole 42mm

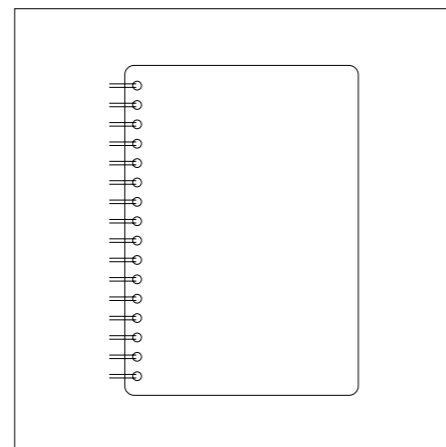

NOTEBOOK
DIN A4, A5, B5

PRODUCT GUIDE

	HUSK				KASSE				COCCO				NATURLA		TALAY		SCAPA	
TRAYS AND PLATES																		
CAPSULE TRAY S/M	•	•	•	•	•	•	•	•	•	•	•	•	•			•	•	•
OVAL TRAY	•	•	•	•	•	•	•	•	•	•	•	•	•			•	•	•
ROUND TRAY	•	•	•	•	•	•	•	•	•	•	•	•	•			•	•	•
TEA TRAY M/L	•	•	•	•	•	•	•	•	•	•	•	•	•			•	•	•
SERVING TRAY	•	•	•	•	•	•	•	•	•	•	•	•	•			•	•	•
LONG TRAY	•	•	•	•	•	•	•	•	•	•	•	•	•			•	•	•
PLATE	•	•	•	•	•	•	•	•	•	•	•	•	•			•	•	•
BOXES AND BOWLS																		
JASMINE BOX S/M	•	•	•	•	•	•	•	•	•	•	•	•	•			•	•	•
TAGINE	•	•	•	•	•	•	•	•	•	•	•	•	•			•	•	•
TAGINE TALL	•	•	•	•	•	•	•	•	•	•	•	•	•			•	•	•
BOWL	•	•	•	•	•					•	•	•	•			•	•	•
CUPS																		
CAPSULE CUP	•	•	•	•	•					•	•	•	•					•
WONDER CUP	•	•	•	•	•					•	•	•	•					•
SAKE CUP	•	•	•	•	•					•	•	•	•					•
PLACEMATS AND COASTERS																		
PLACEMAT SQUARE S/L																•	•	•
PLACEMAT PILLOW S/L																•	•	•
PLACEMAT ROUND S/M/L																•	•	•
COASTER SQUARE																•	•	•
COASTER PILLOW																•	•	•
COASTER ROUND																•	•	•
COASTER PLAIN (SET OF 6)	•	•	•	•	•	•	•	•	•	•	•	•	•			•	•	•
COASTER PATTERN (SET OF 6)	•	•	•	•	•					•	•	•	•			•	•	•
PLANTERS																		
PLANTER SMALL	•	•	•	•	•	•	•	•	•	•	•	•	•			•	•	•
PLANTER TALL	•	•	•	•	•	•	•	•	•	•	•	•	•			•	•	•
BASINS																		
BASIN	•	•	•	•	•					•	•	•	•			•	•	•
NOTEBOOKS																		
NOTEBOOK A4 / A5 / B5	•	•	•	•	•	•	•	•	•	•	•	•	•			•	•	•

CUSTOMIZATION

Since the total production process is made in house, OEM and custom design inquiries are possible. We are able to create new shapes and colors, apply company logos and slogans and, in some cases, create new materials using your waste as raw material. Please contact us for further details.

CONTACT

Sonite Head Office
Sonite Innovative Surfaces Co., Ltd.
253/43 Soi Latphrao 80 (Section 22)
Latphrao Rd., Wangthonglang,
Bangkok 10310 Thailand
T: +66 2935 5575-6
F: +66 2935 5883

Sonite North America
Sonite Innovative Surfaces
Marketing Office
865 Production Place
Newport Beach, CA - 92663 USA
T: +1 949 612 7173
F: +1 949 612 7194

info@sonitesurfaces.com
www.sonitesurfaces.com

INFO

The contents in this catalog are for reference only. Products may vary in shade, tonality, surface finish, color and texture.

Sonite products must be kept away from high heat and fires (including direct sunlight and open flames).

Nothing in this catalog shall be construed in any way to conflict with Sonite's product testing results of sale.

Detailed information of our products and further terms and properties can be found on our website: www.sonitesurfaces.com





WWW.SONITESURFACES.COM